

Pre-Filter

**WATEX
CPFA4**

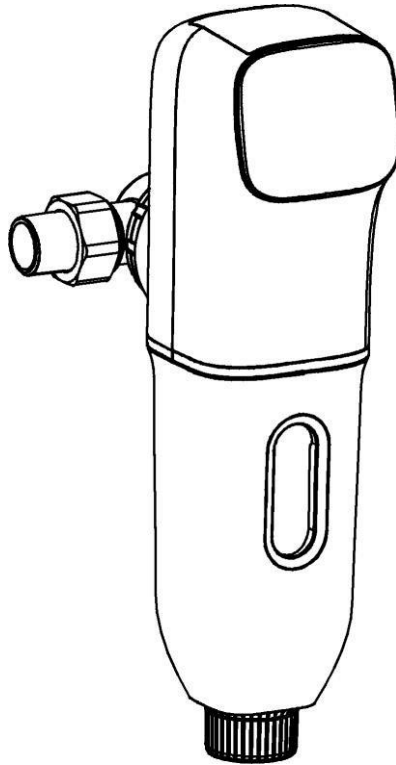

- You must read and understand the contents of this manual before installing or operating your Pre-Filter.
- The pre-filter is designed to remove the particles of impurities, dirt, rust and sediments etc. Protect the downstream equipment such as water filter, water heater, wall-hanging stove, washing machine, shower head etc.
- We guarantee that the pre-filter you receive is complete and reliable, without a qualified installer, do not install, start up or maintain the product personally. The company is not responsible for the product damage, personal injury or property loss as a result of incorrect operation.
- This product is only allowed to be installed in a dry and indoor place, keep it away from heat and children.
- This product is only designed for municipal water supply(5~40°C), do not use it on drain line or corrosive liquid.
- When installing, make sure to observe the correct direction of flow. An arrow on the flange body indicates the direction of flow.
- Pre-filter should be installed directly behind the water metering device and be readily accessible.
- According to different water quality, it is requested to flush the filter every month at the latest.

- Do not damage any part during the process of maintenance.
- The appliance is only to be used with the power supply unit provided with the appliance.

Specification

Product Model	WATEX CPFA4
Filter Mesh	40 μm
Connection Thread	3/4" or 1"
Rated Flow Rate	4 m ³ /h
Ambient Temperature	5~40 °C
Water Supply	Municipal
Suggested Operating Pressure	0.1~0.4 MPa

Exploded View

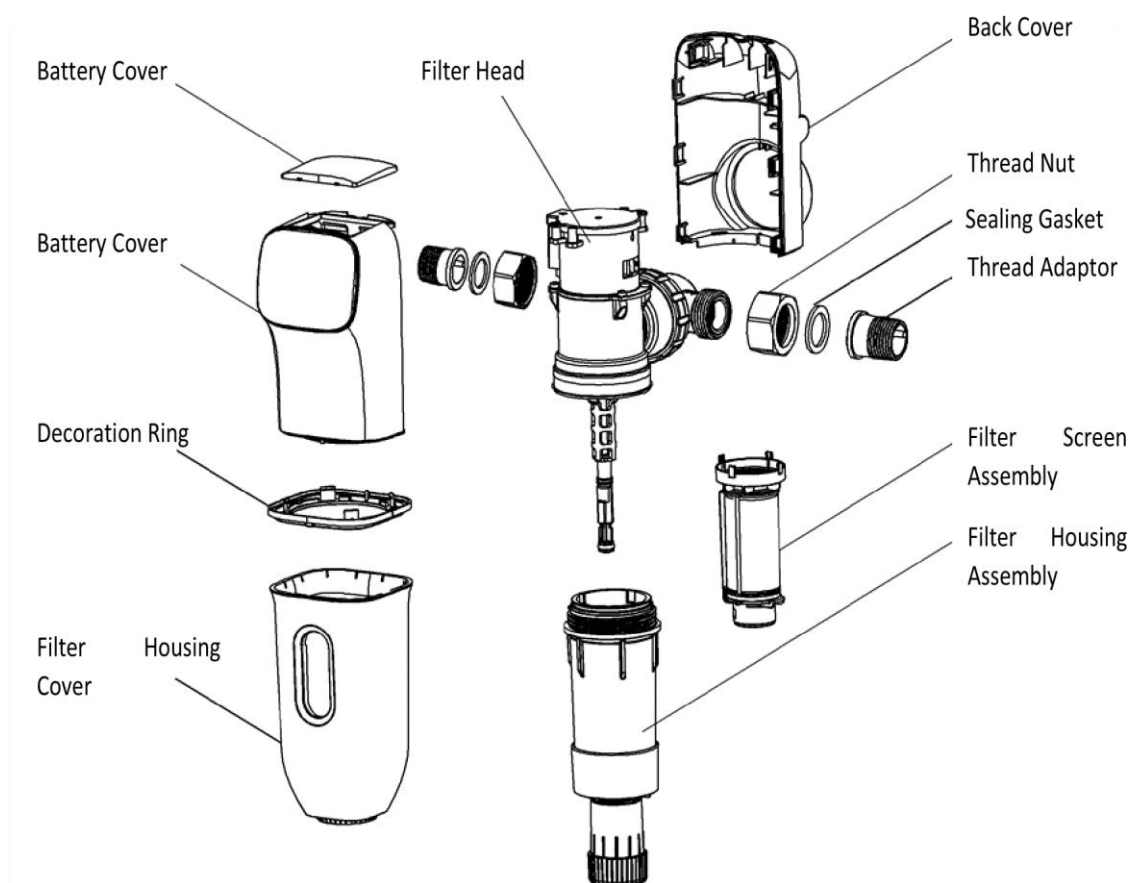

Package Contents

- Pre-Filter Assembly x1
- Manual x1
- Thread Adaptor x2
- Sealing Gasket x3
- Metal Bracket x1
- Filter Housing Wrench x1
- 3/8" Tubing x80cm
- Housing O-ring x1
- Swelling Screw x2
- Self-Tapping Screw x2
- Power Adaptor x1
- 3/8" Ball Valve x1

Product Dimension

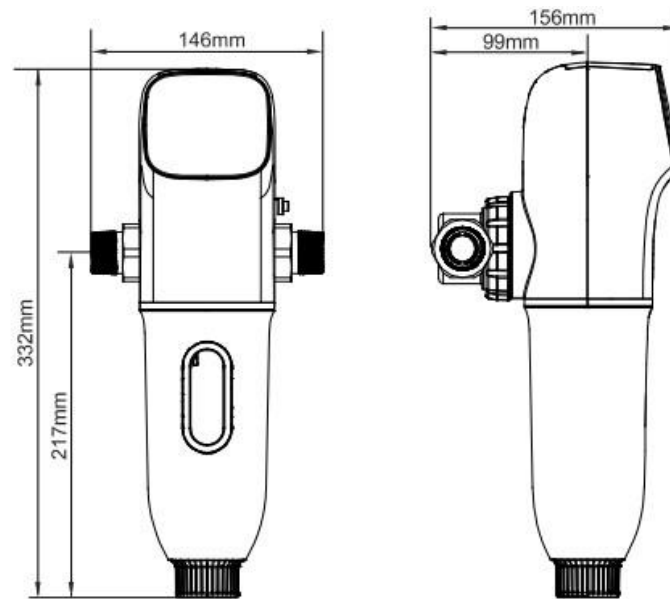

Installation

1

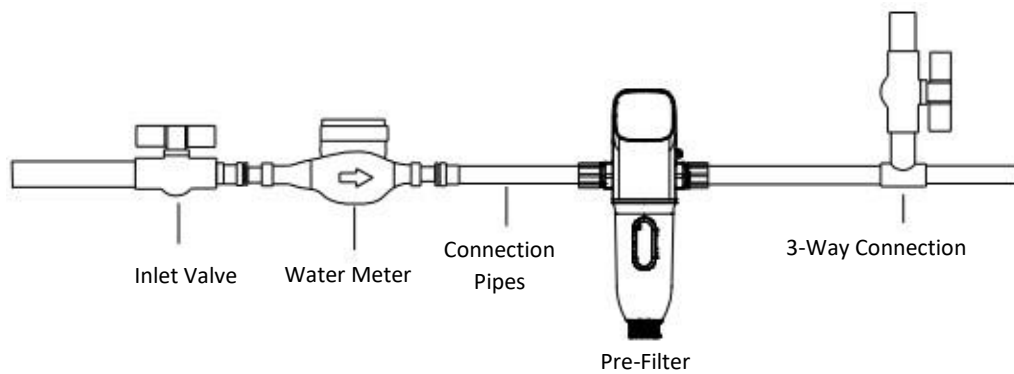

- Close the inlet valve, release the pressure in pipes.
- Install the pre-filter as the figure indicated above.
- When installing, make sure to observe the correct direction of flow. An arrow on the flange body indicates the direction of flow.
- Install the filter with main axis in vertical position.

2

Pre-filter must be installed by a qualified person. Check to ensure the accessories are complete before installation.

- Special welding machine is required if the PPR pipe line are used for plumbing, ensure the pipes are welding securely.

- Extra pipe lines are required if metal pipe line are used for plumbing, please follow the local plumbing codes.

- Do not install the pre-filter outdoors, which are exposed to UV radiation(sunlight), heat, oil or various chemicals.

- Use enough thread tape and make sure it is winding evenly.

- Make sure the other parts are not rotating when you tighten the thread nut.

- After the plumbing work is done, check it thoroughly to make sure if there is any leakage.

-

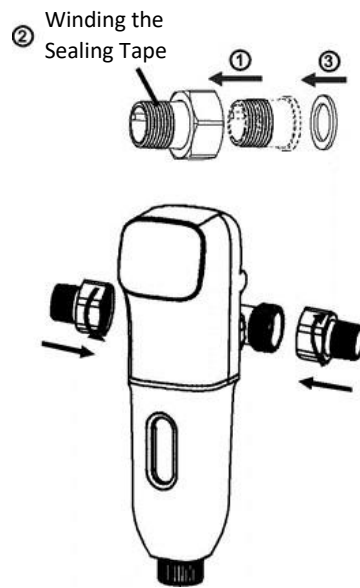

3

- Battery Power Option: remove the battery cover from top, install 3 pcs AA size batteries inside battery box, install back the battery cover.

- Adaptor Power Option: take out the power adaptor provided with the appliance, plug the power cable to the power adaptor socket.

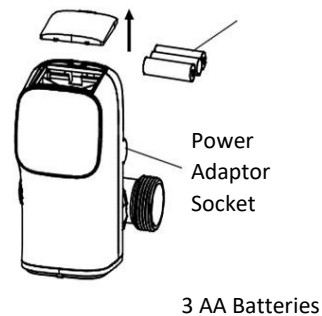

3 AA Batteries

Programming

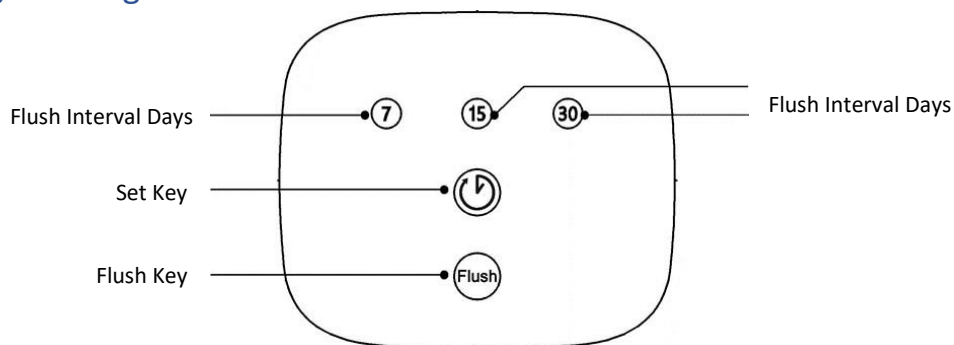

Power first supplied: system beeping meanwhile lights are flashing, with the five lights flashing simultaneously for one time, system enter the factory default setting(15 days), if there is no other operation, system enters sleep mode in 8 seconds.

Awake: touch the "Set" key or "Flush" key to awake the system.

Controller Specification

Power Supply	Battery	Three AA Size Dry Batteries
	Adaptor	Input 100-240V AC 50/60Hz Output 5V DC 1A
Ambient Temperature		5~40 °C
Flush Duration Setting		15s
Flush Interval Setting		7/15/30 Days

Start Up

1. It is required to flush the pre-filter after installation.
2. Before flushing the pre-filter, ensure the drain pipe is connected to drain or it is fine to get one suitable container to gather the drain water.
3. Open the inlet valve to supply raw water.
4. Touch "Flush" key to open the drain port and let the water flush the prefilter for 30 seconds.
5. Touch "Flush" key again to close the drain port, check if there is any leakage.
6. Touch the "Set" key to set the flush interval days, the number of days will be flashing as the set key is touched, touch the "Set" key again until the desired interval days is selected.
7. Your system is ready to use.

Service

1. According to different water quality, it is required to flush the pre-filter once per month at least and flush pre-filter for more than 30 seconds.
2. As the pre-filter is continuously used for 8-12 months, the filter screen may require to be dismantled and clean. (This should be done by a qualified person)
3. Every component should be taken care of during cleaning or maintaining process. (Original spare parts must be used for maintenance)

Maintenance

1. It is suggested to dismantle and clean the filter screen assembly if the contamination can not be removed by the process of normal scrape or flush cleaning.
2. Shut off the inlet water supply, release the water pressure by means of touching the Flush key to set the prefilter to flush position.
3. Screw off the bottom plastic part.(Pic.1)
4. Remove the filter housing cover.(Pic.2)
5. Use the wrench attached in carton box to screw off the filter housing.(Pic.3)
6. Take out the filter screen assembly, then clean the contamination on it.(Pic.4) 7. Take out the scrape cleaning assembly if this part need to be cleaned.(Pic.4)

8. After servicing, reverse following steps to reassemble the pre-filter.

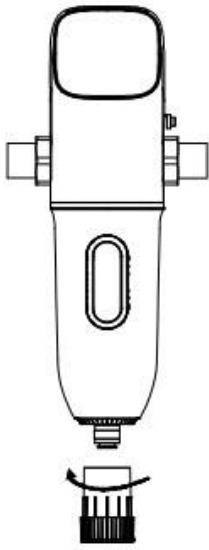

Pic. 1

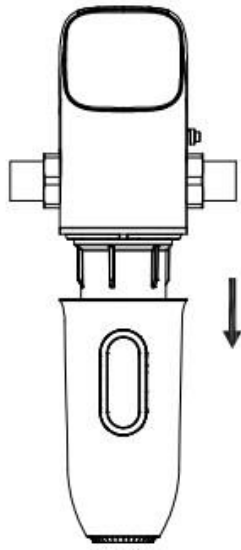

Pic. 2

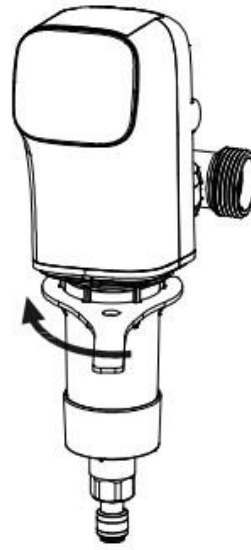

Pic. 3



Pic. 4

Troubleshooting

Problem	Possible Causes	Possible Solution
No Product Water	<ol style="list-style-type: none"> 1. Water supply is shut off. 2. Inlet valve is not open. 	<ol style="list-style-type: none"> 1. Wait water supply restore. 2. Open the inlet valve.
Not Enough Product Water	<ol style="list-style-type: none"> 1. Inlet valve is not fully open. 2. Filter screen is clogged. 	<ol style="list-style-type: none"> 1. Open the inlet valve completely. 2. Flush and clean the filter
Leaks on Connection	<ol style="list-style-type: none"> 1. Connection is not installed well. 2. Connection is not tightened. 3. Not winding enough thread tape. 4. Sealing gasket is aging 	<ol style="list-style-type: none"> 1. Check and make sure the sealing gasket is flat and not be squeezed. 2. Use the wrench to tight it. 3. Use enough thread tape and make sure it is winding evenly.
System Beeping, Lights "30", "15" & "7" Turn Red and Flashing	System can not turn off flushing.	<ol style="list-style-type: none"> 1. Press&hold Set key for 6 seconds to reset program. 2. If Reset process not work, contact dealer.
System Beeping, Lights "30" & "15" Turn Red and Flashing	System can not turn on flushing.	<ol style="list-style-type: none"> 1. Press&hold Set key for 6 seconds to reset program. 2. If Reset process not work, contact dealer.
System Beeping, Light "7" Turn Red and Flashing	Low battery voltage alarm	Replace battery.